

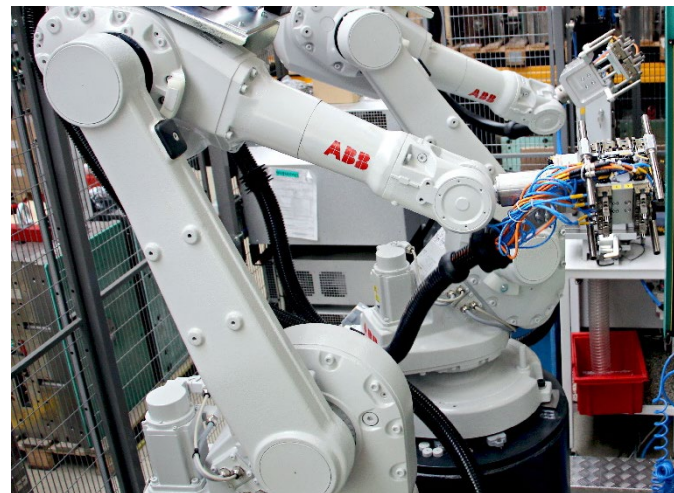

fortell - reliable Czech manufacturer of tools and technical parts

# ABOUT COMPANY

- Czech company with a 30-year tradition, still in the hands of its original founders
- our production takes place in a single manufacturing site within a modern industrial complex in the Czech Republic
- we specialize in high-volume production of **injection-molded plastic and stamped metal parts**, as well as in the design and **manufacturing of injection molds for plastics**
- we currently employ 210 workers



# COMPANY HISTORY 1995-2005

---



**1995**

establishment of private company fortell s.r.o. focused on design and business



**1997**

start of production of metal parts - beginning of stamping department equipped with automatic presses



**2000**

establishment of our tool shop, obtaining of ISO 9001 quality certification



**2003**

founding of injection moulding department – injection moulding

**2004**

we won DHL Export Award for the best exporter among smaller and medium-sized companies throughout the whole Czech Republic

# COMPANY HISTORY 2006-2015

---



**2006**

obtaining of ISO 14001 environmental certification



**2008**

moving of all departments to the new building in summer, modernization of production and logistics

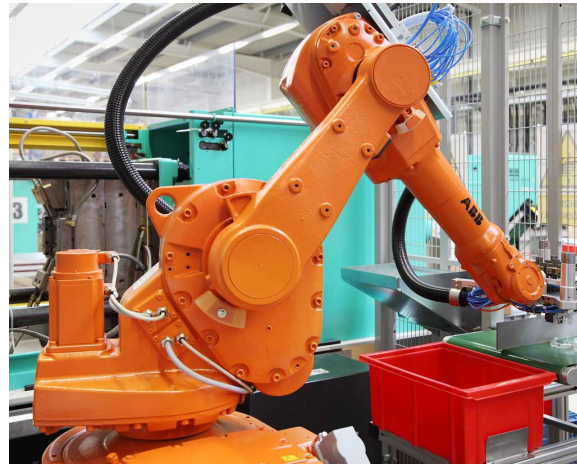

**2011**

significant investments in all production departments



**2013**

implementation of automation in injection moulding department

**2014**

establishment of an independent assembly center

# COMPANY HISTORY 2016-2025

---



**2016**

finishing of a new assembly and warehouse building, obtaining the title Company of the year – Pardubice region



**2021**

purchase of the largest injection molding machine to date – Wittmann Battenfeld 450T

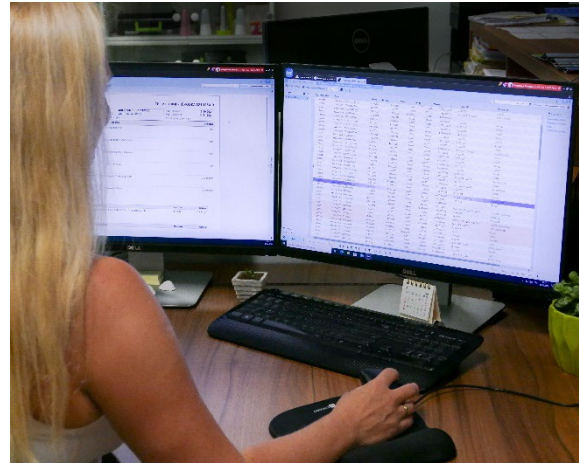

**2023**

new KARAT information system, increased capacity of the warehouse and assembly hall



**2024**

expansion of the assembly center with a new automated workstation

**2025**

a jubilee year celebrating the 30th anniversary of the company's founding

# BASIC STATISTICS

 EMPLOYEES

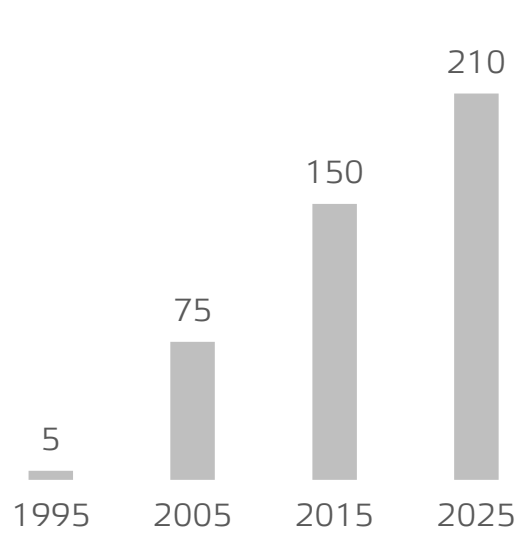

 FLOOR SPACE – sqm

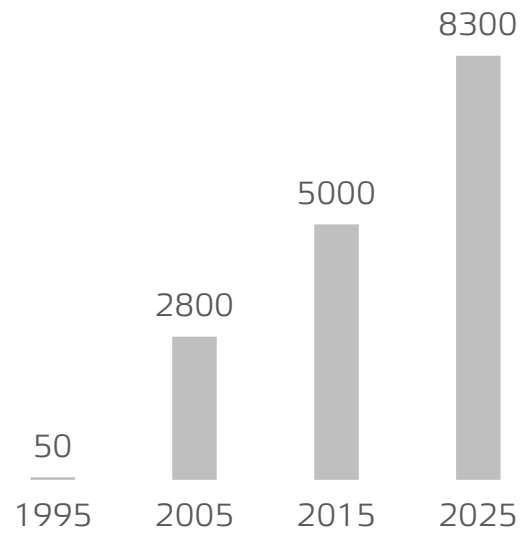

 TURNOVER – mil. EUR

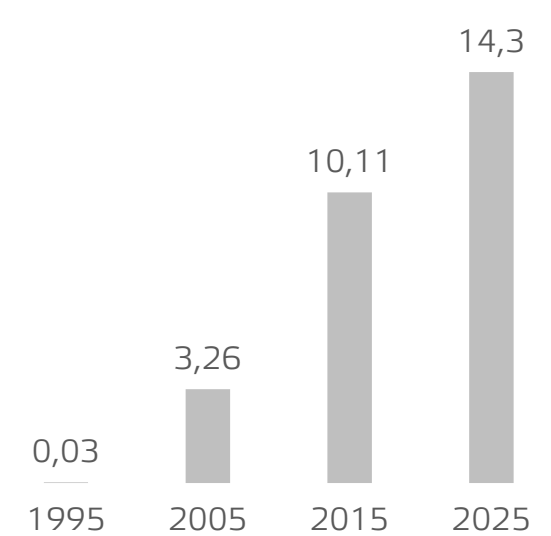

# OUR PRODUCTION ACTIVITIES



PLASTIC PARTS



METAL PARTS



INJECTION MOULDS



SPARE PARTS



DEVELOPMENT AND DESIGN

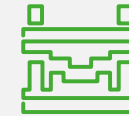

STAMPING TOOLS



FINAL ASSEMBLY



QUALITY CONTROL

# TOOL SHOP



DEVELOPMENT AND DESIGN

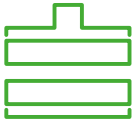

INJECTION MOULDS

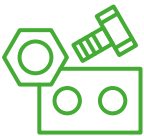

SPARE PARTS



# DEVELOPMENT AND DESIGN

- development and design of single and multicavity moulds and stamping tools
- CAD / CAM system **NX (Siemens)**
- mold-flow software **SIMCON Cadmould**
- 3D printing technology FFF (**Raise3D PRO2**) and SLA (**Creativity LD-006**) methods

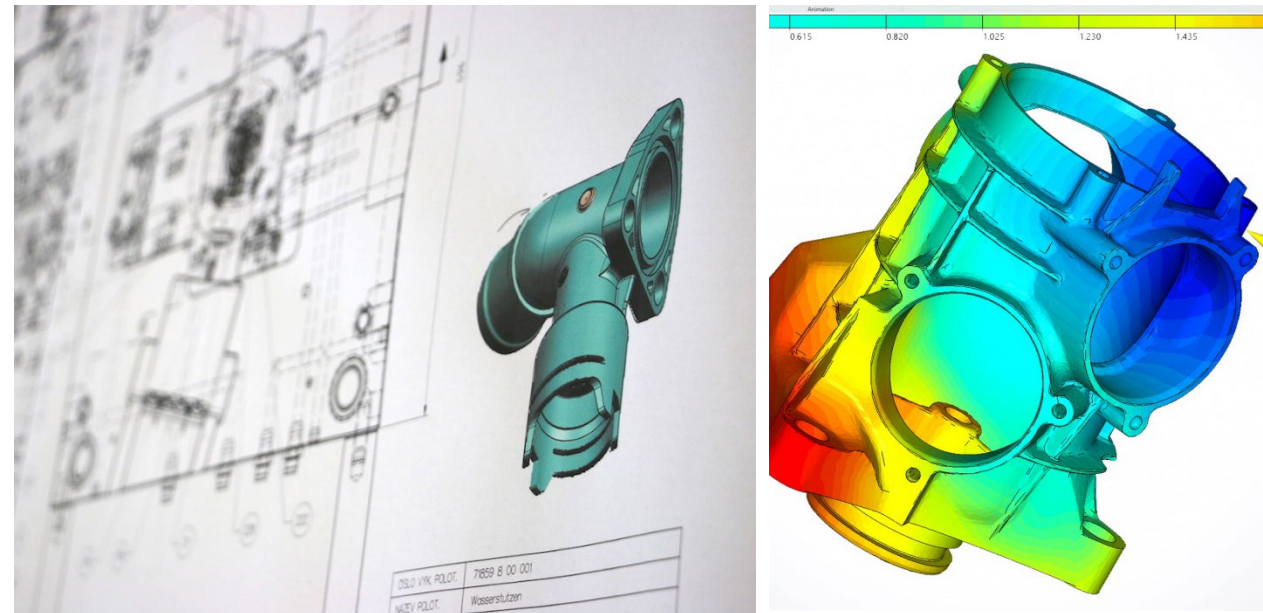
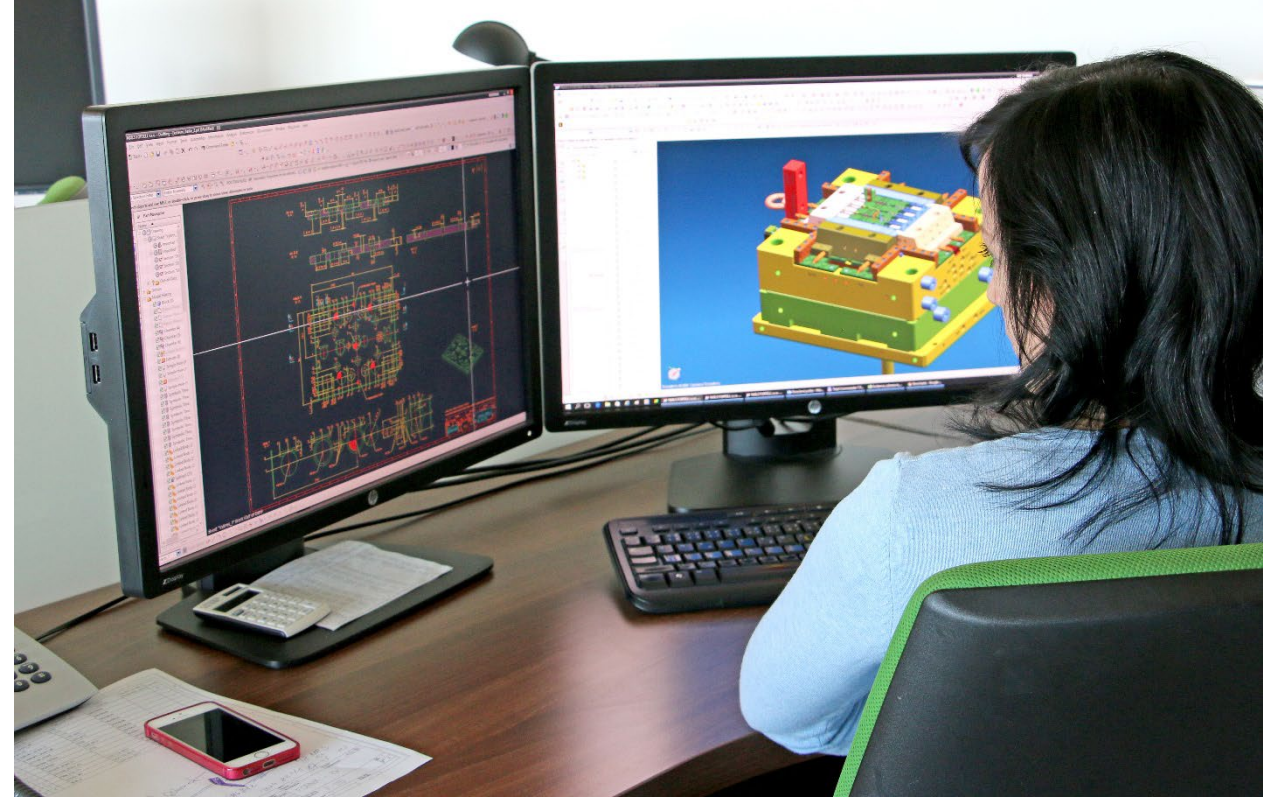

# INJECTION MOULDS

- long-standing experiences (over 2000 moulds)
- single and multicavity moulds with hot runner systems and cold channels, moulds for setting of metal inserts, moulds with hydraulic and pneumatic systems, stack moulds and moulds for thin-walled parts
- maximum weight of injection moulds is 4,5 tons
- production for own injection moulding department and for external customers mainly from the automotive business

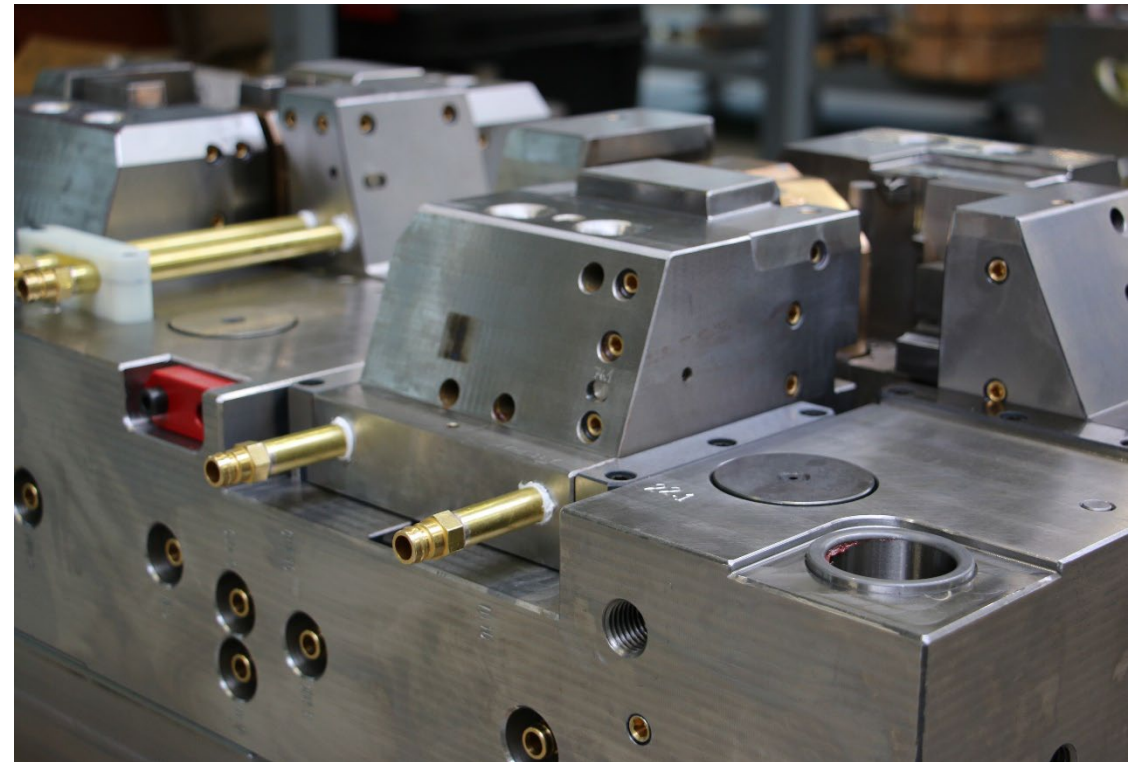
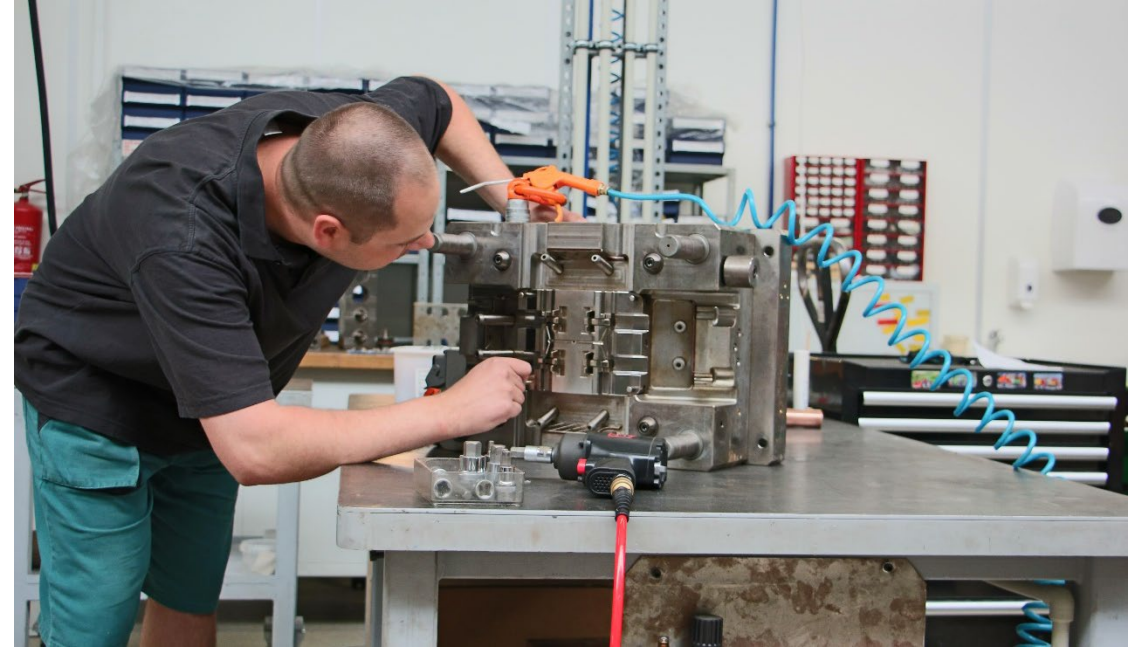

# SPARE PARTS

- production of spare parts for injection moulds, stamping tools and assembly machines
- production of measuring and control jigs
- possibility of digitizing the original part before its production
- emphasizing the accuracy and quality of processing while maximally shortening delivery times





# TOOL SHOP MACHINERY

---

## CNC MACHINING CENTERS

- 5-axis machining center **HERMLE** C42 U, 5-axis machining center **Röders** RXP501DS with RCS pallet system, 3-axis machining center **FIDIA** HS664, **TAJMAC** MCFV 1680, 1060 and **MAS** MCV 750 SPEED

## EDM MACHINES

- cutting machines **AgieCharmilles** CUT 3000, CUT 3000 S, CUT 2000 S and Agiecut Classic 2S, sinking machines FORM P600 and Agietron Innovation 2, drilling machine DRILL 20

## OTHER TECHNOLOGIES

- laser welding machine, milling, surface grinding (**ELB** BL10 grinding machine), drilling and turning



# PRODUCTION OF PLASTIC PARTS



DEVELOPMENT AND DESIGN



INJECTION MOULDS

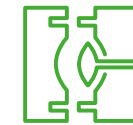

INJECTION MOULDING



FINAL ASSEMBLY



QUALITY CONTROL

# INJECTION MOULDING

- complex services (development and design, injection moulds, injection moulding – incl. parts with metal inserts, final assembly)
- we process technical plastics PA, PC, PS, ABS, PC+ABS, PBT, PMMA, POM, PPA, TPE, PP and many others
- electrotechnical, automotive and consumer industry
- latest injection moulding machines

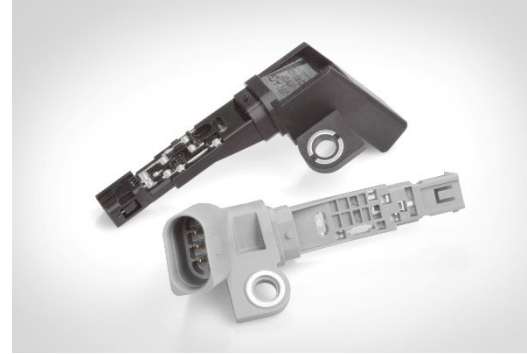

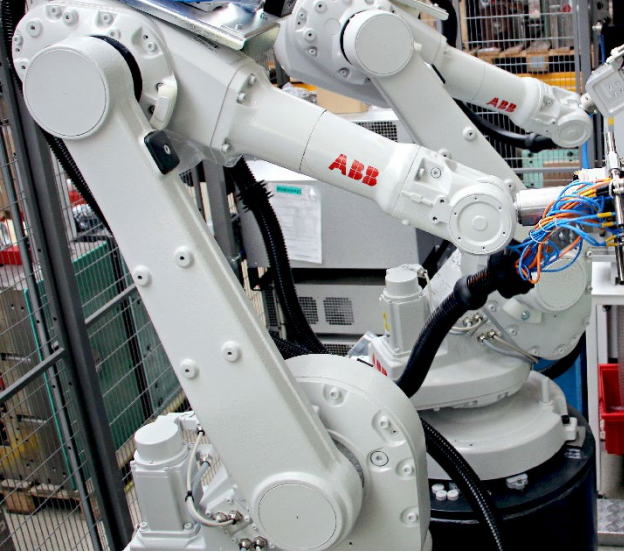

# MOULDING SHOP EQUIPMENT

---

## ELECTRIC AND HYDRAULIC MACHINES

- injection moulding machines **Arburg**, **Wittmann Battenfeld**
- closing force 40–450 tons
- parts with weight up to 1000 grams
- overmoulding of cables and metal inserts

## ROBOTIC SYSTEMS

- 6axis robots **ABB**, 3axis robots **Wittmann**



# PRODUCTION OF METAL PARTS



DEVELOPMENT AND DESIGN

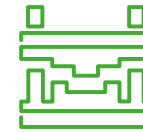

STAMPING TOOLS



METAL STAMPING



FINAL ASSEMBLY



QUALITY CONTROL

# METAL STAMPING

- complex services (development and design, stamping tools, metal stamping, final assembly)
- we process steel and stainless steels, brass, bronze, copper and aluminium including surface treatment and tumbling
- electrotechnical and automotive industry

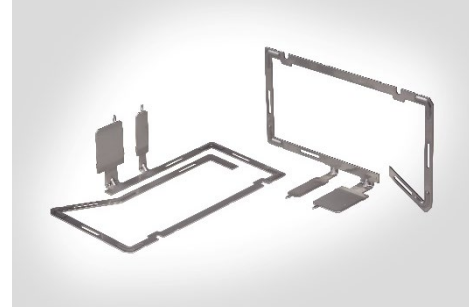



# STAMPING SHOP EQUIPMENT

---

## ECCENTRIC PRESSES

- **EBU** (STA 63/STA 80/STA 160)
- **LEN, LEK** (10–100 tons)
- high-speed press **HAULICK ROOS**
- maximum width of strip is 500 mm and its thickness is 4 mm

# FINAL ASSEMBLY

- assembly of final products by using special purpose machines
- ultrasonic welding of plastic parts even made of different materials
- **DUKANE IQ Servo Press**

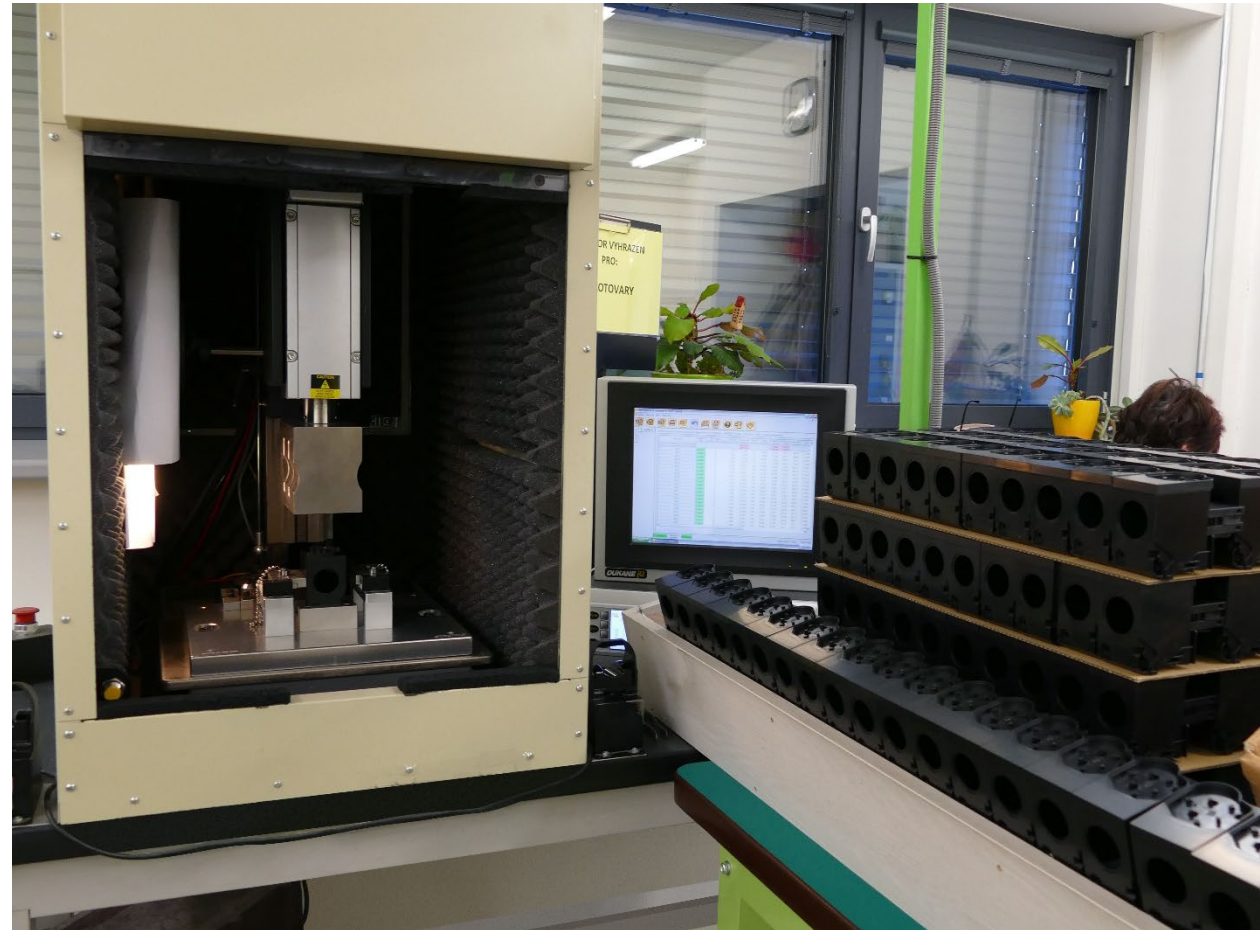
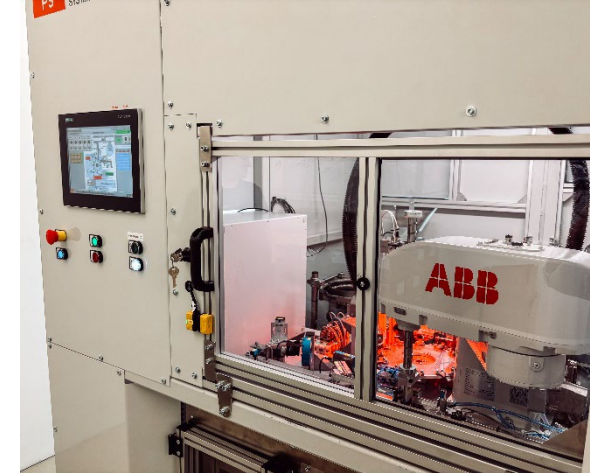

# QUALITY CONTROL

- 3D CMM **Wenzel** LH 87 and LH 65
- 3D CMM **Werth** ScopeCheck FB/Z
- optical 3D Profilometer **Keyence** VR-6000
- 3D measuring microscope **Mitutoyo** MF-B2017C
- climate chamber **WEISS Technik** ClimeEvent C/180/40/3
- Profile projector **Mitutoyo** PJ-A 3000
- SW **Q-DAS/Hexagon** - O-QIS and QS-STAT



# CERTIFICATION

## ČSN EN ISO 9001:2016

- obtained in 2000
- validity of the certificate until 18. 12. 2026

## ČSN EN ISO 14001:2016

- obtained in 2006
- validity of the certificate until 18. 12. 2026

ERTIFIKAT ♦ CERTIFICATE ♦ 認證書 ♦ CERTIFICADO ♦ CERTIF

CERTIF

Certification Body Management  
TÜV SÜD

CZ – 563 01

development  
design

A



CERTIFI

Certification Body Management  
TÜV SÜD Czech s.r.o.  
certifies that



**fortell s.r.o.**  
Nádražní 1111  
CZ – 563 01 Lanškroun, Žichlínské Předměstí  
Ident. No.: 64256197

has established and applies  
the Environmental Management System  
**development in area of engineering sciences**  
**design and production of tools and moulding**  
**stamping of metal parts**  
**injection moulding of plastic parts**  
**assembly**

An audit was performed, Report No. **15.669.793**  
Proof has been furnished that the requirements  
according to

**ČSN EN ISO 14001:2016**  
are fulfilled.

The certificate is valid from **19.12.2023** until **18.12.2026**  
Certificate Registration No. **15.669.739**



# OUR EXPORT AREA

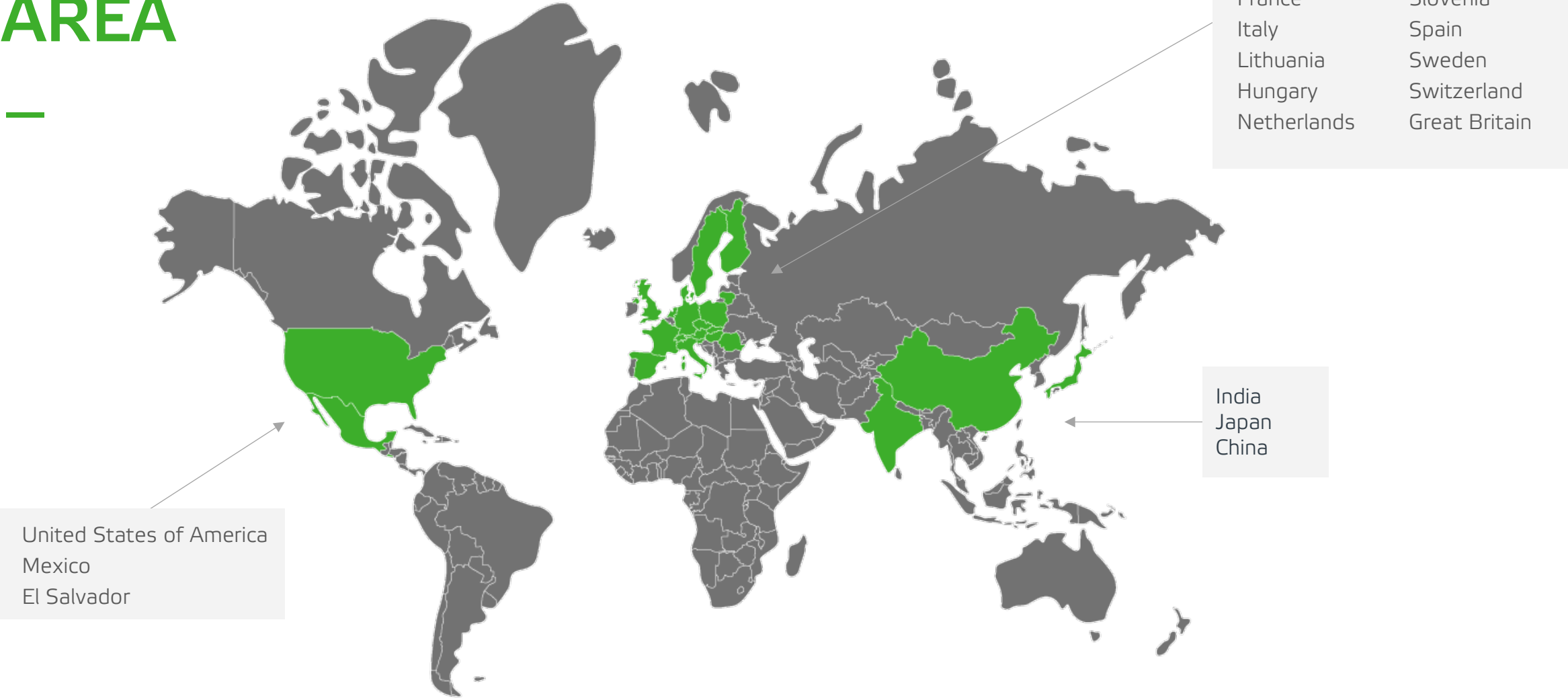



## SHARE OF INDUSTRIES

---



**36 %** ELECTROTECHNICAL INDUSTRY



**32 %** AUTOMOTIVE INDUSTRY



**19 %** CONSUMER INDUSTRY



**13 %** OTHER INDUSTRIES

# OUR MAIN CUSTOMERS

ELECTROTECHNICAL  
INDUSTRY



AUTOMOTIVE  
INDUSTRY



CONSUMER  
INDUSTRY



OTHER  
INDUSTRIES



# WHAT OUR CUSTOMERS SAY ABOUT US

---



"We appreciate the technical expertise, efficiency, and willingness to accommodate our requirements."

**Zbynek Podhorny**, Managing Director, Head of Procurement



"Incredibly smooth and open communication is undoubtedly a tremendous advantage of the company."

**Blanka Chvojkova**, Head of Quality



"The company fortell s.r.o. is our key supplier and key partner."

**Eva Kokorova**, Sales and Purchasing



"Good quality, price, and delivery are key components for us."

**St. Claire Skepple**, Supplies Component Engineer



"The company fortell s.r.o. demonstrates a high level of expertise and know-how in its field."

**Katerina Maderova**, Strategic procurement



"The company's level, both in terms of production capabilities and employees, is at a professional standard."

**Martin Vodak**, Head of Purchasing

# WHY CHOOSE FORTELL?

- we are a **Czech company** with a strong focus on quality and craftsmanship precision
- we build on a fair approach, innovation, and meticulous craftsmanship, **working closely with our partners on development**
- we manufacture **with precision**, think ahead, and seek **the best solutions** for our customers and partners
- **30 years of experience** – we have produced over **2000 molds/tools**, manufacture **300 million parts annually**, and process **1200 tons of material** each year



CZECH COMPANY



RELIABLE  
DEVELOPMENT PARTNER



MODERN COMPANY



30 YEARS OF TRADITION

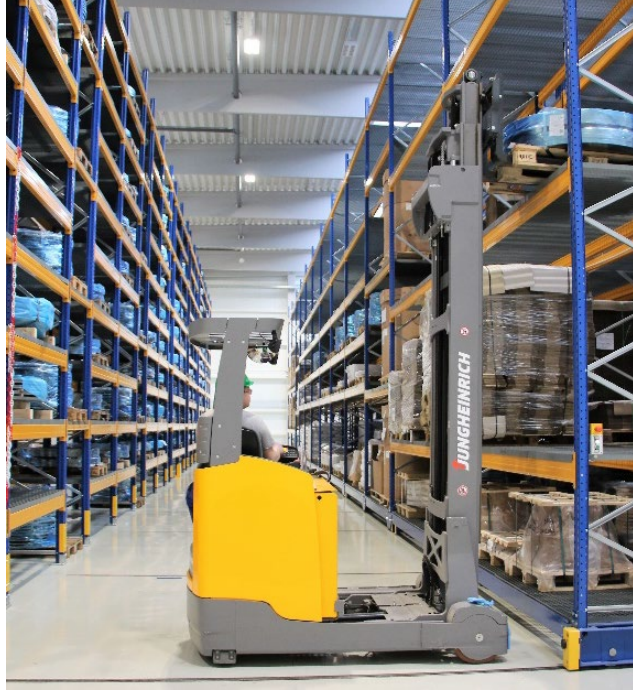



Thank you for your attention  
and don't hesitate to contact us.

#freshfactory

[www.fortell.cz](http://www.fortell.cz)



Nadrazni 1111  
563 01 Lanskrout  
Czech Republic



T: +420 465 466 500  
E: [fortell@fortell.cz](mailto:fortell@fortell.cz)

